

# Nocturnal Bird Migration Over an Appalachian Ridge at a Proposed Wind Power Project

TODD J. MABEE,<sup>1</sup> ABR Inc., Forest Grove, OR 97116, USA

BRIAN A. COOPER, ABR Inc., Forest Grove, OR 97116, USA

JONATHAN H. PLISSNER, ABR Inc., Forest Grove, OR 97116, USA

DAVID P. YOUNG, Western EcoSystems Technology Inc., Cheyenne, WY 82007, USA

## Abstract

Characteristics of nocturnal bird migration are poorly understood for many regions of the United States. This information will be critical in areas where wind power projects are proposed. We used portable marine radar to conduct a nocturnal bird migration study at multiple sites along the Allegheny Front, West Virginia, on 45 nights during autumn 2003, to document migration characteristics at a proposed wind power project. Nocturnal passage rates were highly variable among nights, ranging from 8 to 852 targets/km/hour, with a seasonal mean of  $241 \pm 33$  targets/km/hour at the primary (central) study site and 199 targets/km/hour for the entire proposed development. Mean flight altitudes also were highly variable among nights, ranging from 214 to 769 m above ground level (agl), with a mean flight altitude of  $410 \pm 2$  m agl. Flight directions indicated that most migrants crossed, rather than followed, the Allegheny Front ridgeline. We believe portable marine radars, when coupled with a rigorous study design, can collect important baseline information on avian migration and address site specific questions posed at proposed developments. Concurrent collection of low-altitude migration and avian fatality data could help elucidate which metrics are most useful for predicting avian fatalities at wind power developments. (WILDLIFE SOCIETY BULLETIN 34(3):682–690; 2006)

## Key words

Appalachian Ridge, birds, flight behavior, nocturnal migration, radar, West Virginia, wind power.

The potential for avian fatalities at proposed wind power developments often generates concern and controversy because of the large number of avian fatalities that have been documented at some older wind power developments (e.g., Altamont Pass, Calif., USA; Orloff and Flannery 1992), the relatively small number of avian fatalities at many modern wind power developments (Erickson et al. 2001), and the uncertainty of predicting the number of avian fatalities at future wind power developments (U.S. Fish and Wildlife Service [USFWS] 2003). Most of the avian fatalities at older wind power facilities in the United States (i.e., projects in Calif., such as Altamont Pass) have been of diurnally active, resident raptor species (Orloff and Flannery 1992, Erickson et al. 2001). Because of this concern for raptor fatality, the methods most widely used today to assess the potential for avian fatalities (i.e., point counts) are designed to focus on the study of diurnally active species.

Avian fatalities at modern wind power developments, however, are composed of a large proportion of nocturnal migrants (Osborn et al. 2000, Erickson et al. 2001). Study results have been variable, but passerines typically comprise >80% of fatalities at modern wind power developments (Erickson et al. 2001), with between 20 and 70% of those fatalities involving nocturnal migrants. Passerines may be more at risk of colliding with structures at night because these birds tend to migrate at lower altitudes than do other groups of migratory birds (e.g., lower than waterfowl or shorebirds; Kerlinger 1995). Although large kills of nocturnal migrants have not been documented at wind power developments to date, the rapid expansion of wind power developments throughout the United States, the lack of empirical data assessing the number of nocturnal migrants passing through many regions of the country, and the fact that considerably more birds migrate at night than

during the daytime (Gauthreaux 1975, Kerlinger 1995) warrant the need for studies to investigate the dynamics of nocturnal bird migration at proposed wind power developments (USFWS 2003).

Mobile X-band radar systems (Cooper et al. 1991, Harmata et al. 1999) have been used to characterize nocturnal bird migration in the Pacific Northwest (Mabee and Cooper 2004), Montana (Harmata et al. 1999), New York (Cooper et al. 1995), and New Hampshire (Williams et al. 2001). This technology is well suited for studying low-altitude migration ( $\leq 1.5$  km above ground level [agl]) at wind power development sites and is uniquely able to provide local information about bird flight altitudes, flight direction, behavior, and passages rates (number of targets per kilometer per hour) at a moderate spatial scale (approx. 1.5-km radius around the sampling location). An understanding of the vertical distribution of migratory birds is especially useful because it allows an assessment of passage rates specifically within the heights of modern wind turbines ( $\leq 125$  m agl) and above them. These radar metrics are some of the essential variables for understanding spatial and temporal patterns of nocturnal migration and, therefore, are important components for determining risk of avian collisions with aboveground structures.

Because of the large numbers of passerine species that migrate over the Appalachian Mountains at night and the generally unknown relationship between ridgelines and nocturnal migration patterns (Williams et al. 2001), there is some concern that wind power developments in the Appalachian ridges of the eastern United States pose an elevated risk to migratory birds relative to nonridge areas. Although some diurnally migrating birds concentrate along certain ridgelines in West Virginia (Heintzelman 1975, Bellrose 1976, Hall and Bell 1981, Zalles and Bildstein 2000), few comparable data are available for nocturnal migration for this region.

We used a portable X-band radar system to collect information

<sup>1</sup> E-mail: tmabee@abrinc.com

on the migration characteristics of nocturnal birds (particularly passerines) during autumn 2003 at the proposed Mt. Storm Wind Power Project in West Virginia. Our objectives were to 1) collect and compare information on flight directions, migration passage rates, and flight altitudes of nocturnal migrants at multiple sites near or within the proposed development; and 2) determine if nocturnal migrants follow the Allegheny Front ridgeline within the proposed project area.

## Study Area

The proposed Mt. Storm Wind Power Project is an approximately 300-megawatt development consisting of approximately 150–200 wind turbines (maximal blade height of  $\leq 125$  m), located along the Allegheny Front ridgeline in Grant County, northeastern West Virginia (Fig. 1). The Allegheny Front lies within the Allegheny Mountains physiographic region and along the western edge of the Ridge and Valley physiographic province (Buckelew and Hall 1994). The Allegheny Mountains are characterized by steep to rolling mountains, ridges, high plateaus, hardwood and spruce forests, and are known for their importance for diurnally migrating birds, including raptors and passerines (Hall and Bell 1981, Zalles and Bildstein 2000). Much of the proposed site has been strip-mined for coal and reclaimed, and the remaining forest has been logged both recently and historically.

We selected 3 sites along an approximately 16-km segment of the Allegheny Front (Fig. 1) to investigate variation along the ridge: northern (Universal Transverse Mercator [UTM] 17S 656687E 4346150N, elevation 969 m), central (UTM 17S 653448E 4339695N, elevation 1,049 m), and southern (UTM 17S 648919E 4333424N, elevation 1,042 m). We also selected 2 sites to serve as off-ridge comparison sites to look at variation in flight characteristics over different landforms. The western site (UTM 17S 651519E 4348906N, elevation 861 m) was located on the plateau approximately 6 km west of the front; the eastern site (UTM 17S 657890E 4339759N, elevation 499 m) was located in the valley adjacent to the front and approximately 4 km east of the central ridge site.

## Methods

### Study Design

Between 3 September and 17 October 2003, we conducted 45 nights of radar observations of nocturnal bird migration to overlap with the peak diurnal migratory periods of eastern United States passerines along the Allegheny Front (Hall and Bell 1981). Our study design entailed using one radar at the central site (sampling approx. 6 hr/night) and using a second radar lab to move between 2 secondary sites (i.e., northern, southern, eastern, or western sites) and sample approximately 2.5–3 hours/site/night. We systematically varied observer assignments and starting locations of the second mobile radar lab to minimize bias among sites and observers. Radar surveys occurred between approximately 2030 hours and 0230 hours, providing coverage of the peak period of nocturnal migration for passerines within a night (Lowery 1951, Gauthreaux 1971, Alerstam 1990, Kerlinger 1995).

### Radar Equipment

Each of our mobile laboratories consisted of a van or pickup with a roof-mounted marine radar that could be positioned to function as

both a surveillance and vertical radar. In the horizontal position (surveillance mode), the radar scanned the surrounding area around the lab, and we manually recorded information on flight direction, flight behavior, passage rates, and groundspeeds of birds. With the radar antenna placed in the vertical position, we measured flight altitudes of targets with an index line on the monitor relative to ground level where the radar was located. We recorded all data manually into a laptop computer. A description of a similar radar laboratory can be found in Cooper et al. (1991). A similar vertical radar configuration was described by Harmata et al. (1999, 2003), and sampling methods followed Mabee and Cooper (2004).

The radar (Furuno Model FR-1510 MKIII; Furuno Electric Company, Nishinomiya, Japan) was a standard marine radar transmitting at 9.410 GHz (i.e., X-band) through a 2-m-long slotted waveguide (antenna) with a peak power output of 12 kW. We set pulse length at 0.07 microseconds and operated the radar at the 1.5-km range setting. The antenna had a beam width of  $1.23^\circ$  (horizontal)  $\times$   $25^\circ$  (vertical) and sidelobes of  $\pm 10$ – $20^\circ$ . Range accuracy is 1% of the maximal range of the scale in use or 30 m (whichever is greater); bearing accuracy is  $\pm 1^\circ$ .

### Data Collection

**Target identification.**—The term “target,” rather than “flock” or “individual,” is used to describe animals detected by radar because the species composition and size of a flock of birds usually was unknown. Based on the study period and location, we assumed that the majority of targets we observed were passerines, which generally do not migrate as tight flocks (Lowery 1951, Kerlinger 1995, T. J. Mabee and B. A. Cooper, ABR Inc., personal observation). Thus, we assumed that targets generally represented single individuals. Differentiating the various target types encountered (e.g., birds, bats, insects) is central to any radar study, especially with X-band radars that can detect small flying animals. Because bat flight speeds overlap with flight speeds of passerines (i.e., are  $>6$  m/sec; Tuttle 1988, Larkin 1991, Bruderer and Boldt 2001, Kunz and Fenton 2003), it was not possible to separate bird targets from bat targets based solely on flight speeds. An unknown proportion of bats, therefore, were included in our data from this study. The proportion of bats migrating at low altitudes may have decreased over the course of our study, however, as most bat fatalities at wind power developments appear to occur between approximately mid-July and late September (Johnson 2004).

Of primary importance, however, is the elimination of insect targets as they were not of interest in this particular study. We used a combination of techniques to reduce insect contamination in the data and omitted either individual sampling sessions or whole nights when insect densities hampered identification of bird-like targets. We reduced insect contamination by 1) omitting small targets (the size of gain speckles) that only appeared within approximately 500 m of the radar and targets with poor reflectivity (e.g., targets that plotted erratically or inconsistently in locations having good radar coverage); 2) editing data prior to analyses by omitting surveillance radar targets with corrected airspeeds  $<6$  m/second (following Diehl et al. 2003); and 3) excluding all vertical data collected during sessions in which corresponding surveillance data indicated that  $>10\%$  of targets had airspeeds  $<6$  m/second.

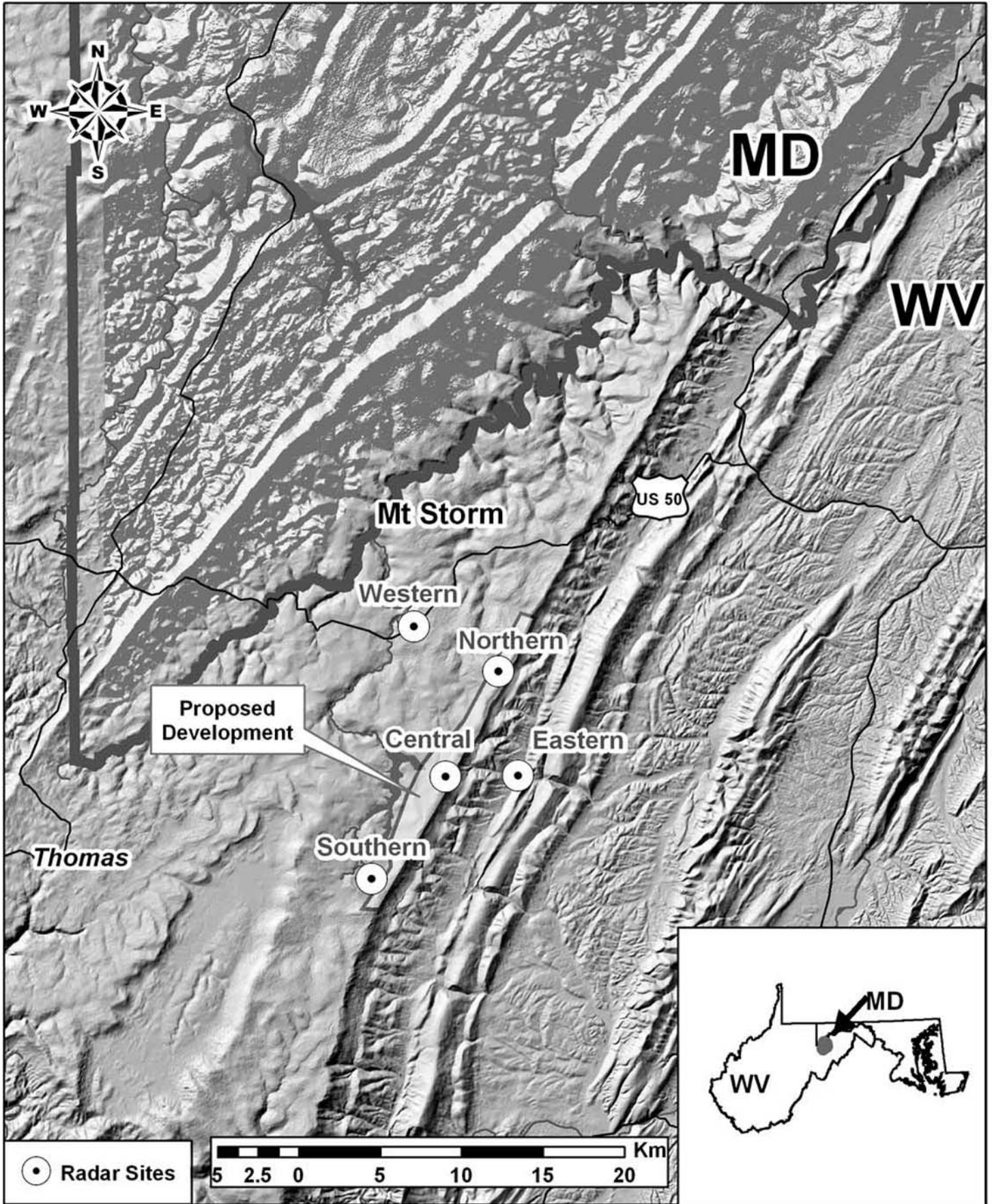

**Figure 1.** Locations of the radar sampling sites and the proposed Mt. Storm wind power development, West Virginia, USA.

The 6 m/second airspeed threshold was based on radar studies that have determined that most insects have an airspeed of <6 m/second, whereas that of birds and bats usually is  $\geq 6$  m/second (Tuttle 1988, Larkin 1991, Bruderer and Boldt 2001, Kunz and Fenton 2003).

**Sampling design.**—Each of the 6 60-minute nocturnal radar sampling sessions/night included: 1) one 10-minute session to collect weather data and adjust the radar to surveillance mode; 2) one 5-minute session with the radar in surveillance mode (1.5-km range) for collection of information on migration passage rates; 3) one 10-minute session with the radar in surveillance mode (1.5-km range) for collection of information on ground speed, flight direction, tangential range (minimal perpendicular distance to the radar laboratory), transect crossed (the 4 cardinal directions—north, south, east, and west), species (if known), number of individuals (if known), flight behavior (approached and crossed ridge; approached but did not cross ridge; approached, turned but still crossed ridge; did not approach ridge; unknown), and location (west of ridge, over ridge, east of ridge); 4) one 10-minute session to adjust the radar to vertical mode; and 5) one 10-minute session with the radar in vertical mode (1.5-km range) to collect information on flight altitudes <1.5 km agl. The vertical radar was oriented so that it collected data along a southeast–northwest transect that was approximately perpendicular to the Allegheny Front ridgeline.

Weather data collected at the beginning and middle of each hour consisted of ground-level wind speed, wind direction, cloud cover, ceiling height, visibility, precipitation, and air temperature. We also obtained wind speed and direction from 2 50-m-high meteorological towers located near our central and northern sites.

## Data Analyses

**Treatment of radar data.**—Radar data were not corrected for differences in detectability with distance from the radar unit. Thus, our passage rate estimates (and other estimates derived from passage rates) should be considered an index of the actual number of birds and bats passing through the area. We computed airspeeds (i.e., ground speed corrected for wind speed and direction) of surveillance radar targets with the formula

$$V_a = \sqrt{V_g^2 + V_w^2 - 2V_g V_w \cos\theta},$$

where  $V_a$  = airspeed,  $V_g$  = target groundspeed (as determined from the radar flight track),  $V_w$  = wind velocity, and  $\theta$  is the difference between the observed flight direction and the direction of the wind vector. Targets with corrected airspeeds <6 m/second (4%) were deleted from all analyses.

We analyzed flight-direction data following procedures for circular statistics (Zar 1999) with Oriana software version 2.0 (Kovach 2003). The dispersion of flight directions is presented as the mean vector length ( $r$ ), which varies from a value of 0 (maximal dispersion) to 1 (maximal concentration). Migration passage rates are reported as the mean  $\pm 1$  standard error (SE) of the number of targets passing across 1 km of migratory front per hour (targets/km/hr  $\pm 1$  SE). We corrected passage rates and altitudes to account for the portion of the 1.5-km sampling radius (<10%) that we could not sample because of ground clutter or radar shadow.

We investigated flight behaviors by analyzing target behaviors recorded directly during surveillance radar sessions. We consid-

ered targets to have reacted to the ridge if they exhibited a change in flight direction of  $\geq 10^\circ$  while crossing the ridge.

For calculations of the daily patterns in migration passage rates and flight altitudes, we assumed that a day began at 0700 hours and ended at 0659 hours, so that a sampling night was not split between 2 dates. We used repeated-measures ANOVA, with the Greenhouse–Geisser epsilon adjustment for degrees of freedom, to compare passage rates and flight altitudes among hours of the night for nights with complete sampling (i.e., all 6 sessions). Factors that decreased our sample size of the various summaries and analyses included insect contamination and precipitation. The level of significance ( $\alpha$ ) for all tests was set at 0.05. All flight-altitude data are presented in meters above ground level relative to a horizontal plane passing through the radar-sampling site.

**Site comparisons.**—Because our study design consisted of pairs of sites sampled simultaneously, analyses of site-specific variation in migration patterns are presented as paired comparisons (i.e., central:northern, central:southern, central:eastern, central:western). Using concurrently collected data is important because of the large variation in passage rates and flight altitudes within and among nights. Because of the differences in elevation, our comparisons between the central site (at the top of the ridge) and the eastern site (550 m lower than the ridgetop, at the bottom of a valley) are valid only for comparing the same relative sampling space above ground level (agl). We used nonparametric tests in all paired comparisons because our data did not meet assumptions of normality. We used the Mardia–Watson–Wheeler (Uniform Scores) test for paired comparisons with flight directions and Wilcoxon paired-sample tests for comparisons of passage rates and flight altitudes. We conducted flight-direction analyses with Oriana software version 2.0 (Kovach 2003) and conducted the remaining analyses with SPSS software (Statistical Package for the Social Sciences [SPSS 2002]).

## Results

### Flight Direction

At the central site, most radar targets were traveling in a southerly direction, with a mean flight direction of  $184^\circ$  for the entire autumn season ( $r = 0.44$ ;  $n = 4,260$  targets; Fig. 2). Most (82%) of the nocturnal targets were traveling in a southerly direction, with half (51%) of the flight directions between southeast ( $135^\circ$ ) and southwest ( $225^\circ$ ).

Mean flight directions at the central site did not differ from those of corresponding sessions at the northern, southern, and western sites (all comparisons with  $W < 4.00$ ,  $P > 0.200$ ,  $n = 18$ –22). In contrast, mean flight directions differed for the central and eastern sites ( $W = 19.25$ ,  $P < 0.001$ ,  $n = 17$ ; Table 1).

### Flight Behavior

For 952 targets observed at the central site, the flight path plotted long enough on the radar monitor to determine if targets reacted to the ridge while crossing it. The vast majority (90.5%) of targets did not alter their flight direction while crossing the ridge (Table 2). The remaining targets either shifted their flight direction by at least  $10^\circ$  (8.9%) or did not cross the ridge (0.6%)—both considered reactions to the ridgeline (Table 2).

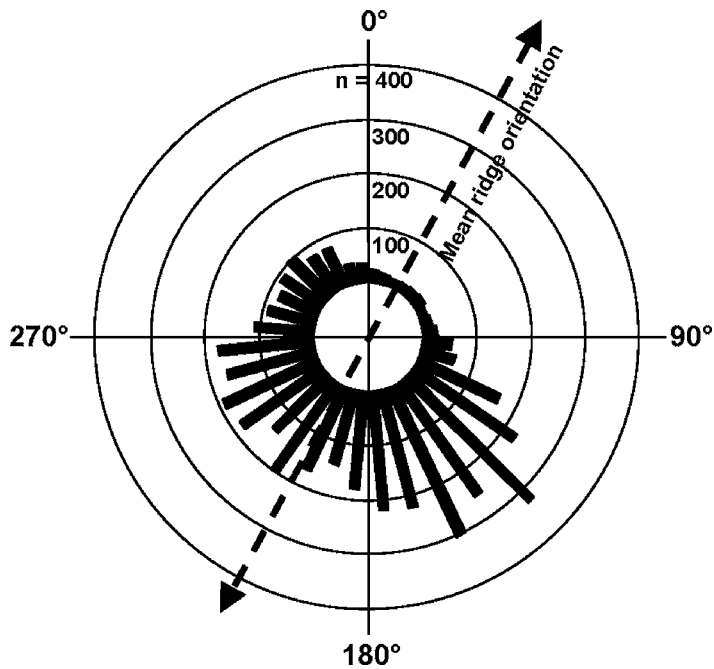

**Figure 2.** Flight directions of radar targets at the Mt. Storm central site, West Virginia, USA, autumn 2003.

### Passage Rates

The mean nocturnal passage rate for the entire autumn season at the central site was  $241 \pm 33$  targets/km/hour ( $n = 40$  nights). Mean nightly passage rates were highly variable during the study, with rates varying from 8 to 852 targets/km/hour (Fig. 3). Passage rates also varied among hours of the night between 2030 hours and 0230 hours ( $F_{3,5, 92} = 2.751, P = 0.039, n = 27$  nights; Fig. 4), with lowest rates typically occurring during the earliest session of the night. Passage rates did not differ between the central and northern sites ( $Z = -1.49, P = 0.136, n = 17$ ). In contrast, they were higher at the central site than at the southern, eastern, and western sites (all comparisons with  $Z < -1.96, P \leq 0.05, n = 18-21$ ; Table 1).

**Ridgeline passage rate.**—Based on the results of the paired comparisons, we estimated that the mean nocturnal passage rates along the ridgeline were 186 targets/km/hour (northern), 241

targets/km/hour (central), and 169 targets/km/hour at the southern site. Averaging across these sites, the mean ridgeline passage rate was 199 targets/km/hour.

### Flight Altitudes

The mean nocturnal flight altitude observed on vertical radar (1.5-km range) at the central site was  $410 \pm 2$  m agl ( $n = 17,543$  targets; median = 350 m agl). Mean flight altitudes were highly variable among nights and ranged from 214 to 769 m agl (Fig. 5). Mean flight altitudes generally peaked early in the evening and then declined ( $F_{3,3, 56.8} = 4.01, P = 0.009, n = 18$  nights; Fig. 6). Mean altitudes late in the evening (0200 hours; 387 m agl), were lower than earlier in the evening (2200 hours; 496 m agl). At the central site, the overall distribution of flight altitude targets in 100-m categories ranged from 11.9 to 15.6% within 500 m agl and then the percentage decreased steadily as altitudes increased (Table 3). The maximal height of the proposed wind turbines (125 m) contained 16% of all targets.

Mean flight altitudes at the central site did not differ from those of corresponding sessions at the northern, southern, and western sites ( $Z > -0.68, P > 0.49, n = 15-21$ ). In contrast, they were significantly different from those at the eastern site ( $Z = -2.02, P = 0.04, n = 16$ ; Table 1).

### Discussion

We documented some of the key migration characteristics (flight directions, timing of migration, passage rates, and flight altitudes) using a paired-plot study design at the proposed Mt. Storm Wind Power Development area along the Allegheny Front in eastern West Virginia. These baseline data may be useful to describe key characteristics of nocturnal bird migration at the proposed development, address specific questions raised about nocturnal bird migration (e.g., do nocturnal migrants concentrate along the Allegheny Front?), and create metrics that may be used to help estimate the potential for migrants to collide with proposed structures. Our results are specific to the autumn period of passerine migration, as spring migration may differ in both geographical patterns of movements (e.g., blackpoll warblers; Hunt and Eliason 1999) and migratory flight characteristics

**Table 1.** A comparison of flight directions, overall passage rates, and flight altitudes of radar targets at the central and other sites near Mt. Storm, West Virginia, USA, during autumn 2003 ( $n$  = number of nights surveyed).

Migration metrics	Site	$n$	Comparison site		Central site		Test statistic <sup>a</sup>		
			Mean	Dispersion <sup>b</sup>	Mean	Dispersion <sup>b</sup>	Z	W	P
Mean flight direction (degrees)	Northern	18	197°	0.58	177°	0.56	1.40	0.496	
	Southern	22	191°	0.53	207°	0.42	1.06	0.588	
	Eastern	19	193°	0.91	178°	0.31	19.25	<0.001	
	Western	17	219°	0.70	191°	0.36	3.23	0.199	
Mean passage rate (targets/km/hr)	Northern	17	225	57	292	66	-1.49	0.136	
	Southern	21	168	31	239	37	-1.96	0.050	
	Eastern	21	54	10	220	52	-3.77	<0.001	
	Western	20	127	22	230	47	-2.70	0.007	
Mean flight altitude (m above ground level)	Northern	16	448	29	439	37	-0.52	0.605	
	Southern	21	447	31	467	33	-0.57	0.566	
	Eastern	16	509	23	427	41	-2.02	0.044	
	Western	17	436	20	472	30	-0.97	0.332	

<sup>a</sup> Test statistics are for Wilcoxon paired-sample test (Z) and Mardia-Watson-Wheeler (Uniform Scores) test (W).

<sup>b</sup> Mean vector length ( $\bar{r}$ ) for directional data; standard error of the mean (SE) for passage rates and flight altitudes.

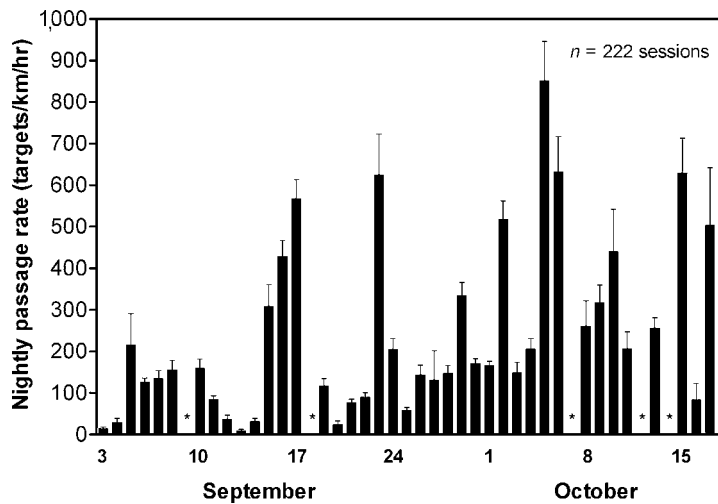

**Figure 3.** Mean passage rates (targets/km/hr  $\pm$  1 SE) at the Mt. Storm central site, West Virginia, USA, autumn 2003. Asterisks denote nights not sampled.

(Blokoel and Burton 1975, Bellrose 1976, Cooper and Ritchie 1995, Harmata et al. 2000). Furthermore, our limited sampling range (1.5 km) and single season of data limit our ability to make predictions on the nocturnal migration characteristics of autumn migrants in other years or at different locations, especially under different weather conditions.

### Migration Characteristics

**Flight directions.**—Mean flight directions of radar targets typically were in the expected direction during autumn migration (i.e., southerly), although directions varied from south-southeast (the principal direction of autumn movement for Neotropical migrants) to the southwest (the principal direction of autumn migration for North American migrants; Drury and Keith 1962, Williams et al. 1977).

**Timing of migration.**—The timing of nocturnal migration is important both within nights and within seasons. In our study passage rates increased approximately 1–2 hours after sunset, leveled off, and then decreased slightly later in the evening (i.e., approx. 0200 hours). Several studies have found a pattern similar to this, in which the intensity of nocturnal migration begins to increase approximately 30–60 minutes after sunset, peaks around

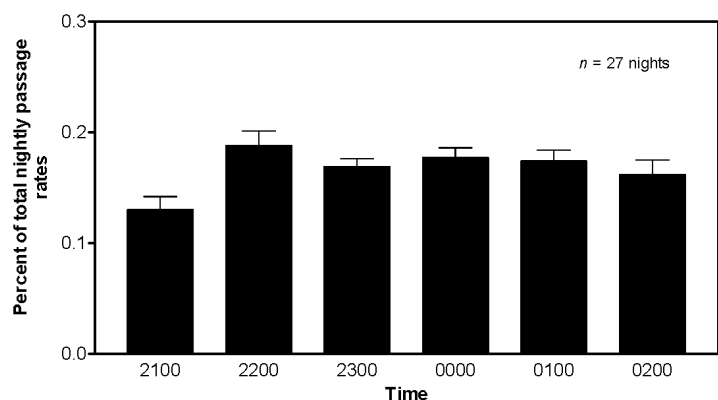

**Figure 4.** Percent of seasonal passage rates ( $\pm$  1 SE) by hour of the night at the Mt. Storm central site, West Virginia, USA, autumn 2003. Each hour includes sampling times within 30 minutes before and after the time shown.

**Table 2.** Flight behavior of radar targets observed on surveillance radar at the Mt. Storm central site, West Virginia, USA, during autumn 2003 ( $n$  = number of radar targets).

Flight behavior	React to ridge	% radar targets	$n$
Approached and crossed ridge	No	90.5	861
Approached, turned $\geq 10^\circ$ , and crossed ridge	Yes	8.9	85
Approached and did not cross ridge (flew parallel to or away from ridge)	Yes	0.6	6
Total		100.0	952

midnight, and declines steadily thereafter until dawn (Lowery 1951, Gauthreaux 1971, Kerlinger 1995, Farnsworth et al. 2004).

Nocturnal migration often is a pulsed phenomenon seasonally as well (Alerstam 1990, Mabee and Cooper 2004). In this study, relatively large movements of birds ( $>400$  targets/km/hr) occurred on 22.5% of the nights studied (16, 17, and 23 Sep, and 2, 5, 6, 10, 15, and 17 Oct). The high daily variation in migration passage rates during the autumn illustrates the importance of continuous sampling throughout the entire autumn migration period to identify important peak migration nights. These peaks may correspond with factors that are predictable only within a short time span (such as passage of weather fronts); however, multiyear studies can provide resolution of general patterns of peak movements within the migratory season, narrowing the range of days in which peaks are likely to occur.

**Passage rates.**—The radar passage rate is an index of the number of migrants flying over a location and can be used as one measure to assess the relative biological importance of sites being considered for wind power development (both within and between different developments). In this study, mean passage rates were similar in paired comparisons between the central and northern sites but were significantly lower at the southern (30% lower), western (45% lower), and eastern (75% lower) sites relative to the central site. Lower passage rates at the eastern (valley) site can be explained by the combination of birds maintaining altitude after crossing the

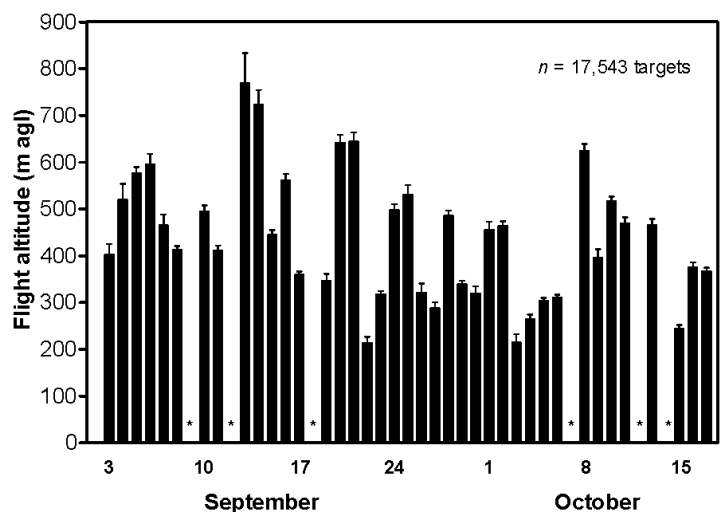

**Figure 5.** Mean flight altitudes (m above ground level [agl]  $\pm$  1 SE) at the Mt. Storm central site, West Virginia, USA, autumn 2003. Asterisks denote nights not sampled.

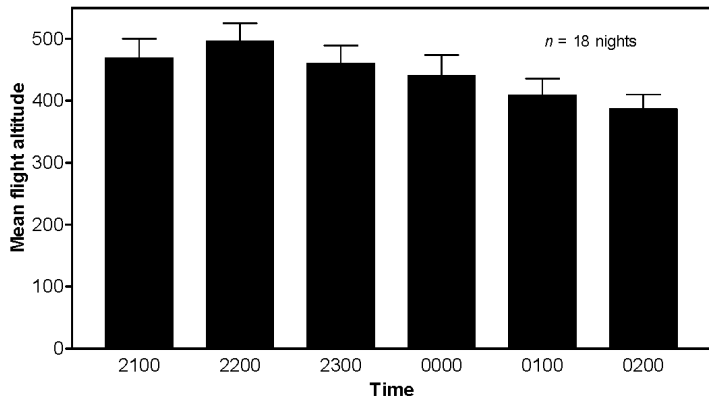

**Figure 6.** Mean flight altitude (m above ground level [agl]  $\pm$  1 SE) by hour of the night at the Mt. Storm central site, West Virginia, USA, autumn 2003. Each hour includes sampling times within 30 minutes before and after the time shown.

ridge (and not dropping down into the valley) and the limited height sampled by the surveillance radar, although data from the other sites show that passage rates may vary within a relatively small area of the landscape (within approx. 10 km of the central site). This suggests that multiple sampling sites may increase the accuracy of passage rates for a proposed development of this size. The pattern we observed, however, does not address larger-scale questions of broad front migration (Berthold 1993, Hutto 2000) that may be



Mobile radar lab in surveillance mode.

**Table 3.** Nocturnal flight altitudes of radar targets (percent of targets) detected at the 1.5-km range at the Mt. Storm central site, West Virginia, USA, during autumn 2003 ( $n = 17,543$  targets).

Flight altitude (m above ground level)	% radar targets
0–100	12.7
101–200	15.6
201–300	14.8
301–400	13.3
401–500	11.9
501–600	9.2
601–700	6.9
701–800	5.1
801–900	3.5
901–1,000	2.9
1,001–1,100	1.7
1,101–1,200	1.2
1,201–1,300	0.7
1,301–1,400	0.3
1,401–1,500	0.1

better studied with a more widespread array of marine radars, or a single radar operating at a larger scale (e.g., WSR-88D radar).

Putting our passage rate results from this study in context is difficult, as there are few published data on autumn nocturnal passage rates available for other locations in the eastern United States. On a broad scale, however, our study area appeared to have higher rates of migration compared to other locations where we have conducted studies using similar equipment and methods. For example, the passage rates from this study (199 targets/km/hr for the ridge-wide estimate, 241 targets/km/hr for the central site) are most similar to 4 sites studied in New York, where passage rates varied from 122 to 238 targets/km/hour (B. A. Cooper, unpublished data) but were higher than at 4 sites in the Midwest (25–100 targets/km/hr; R. H. Day, ABR Inc., unpublished data) and the Pacific Northwest (17–28 targets/km/hr; Mabee and Cooper 2004).

**Flight altitudes.**—Flight altitudes are critical for understanding the vertical distribution of nocturnal migrants and are another important metric used to assess the risk of collision for wind power developments. Relative to other bird groups migrating over land, passerines tend to migrate at lower flight altitudes, whereas shorebirds and waterfowl tend to migrate at higher altitudes (Kerlinger 1995). Because we know that birds often were flying above 1.5 km in this study (at least one target was recorded flying from 1,500 to 3,000 m agl during 85% of the nights sampled on the 3.0-km range), our mean flight altitudes (410 m agl) based on 1.5-km-range data are minima, and the percentages of targets within 100-m strata are maxima.

Similar to our results, most other studies, using a variety of radar systems and analyses, have indicated that the majority of nocturnal migrants fly below 600 m agl (Bellrose 1971, Bruderer and Steidinger 1972, Gauthreaux 1972, 1991, Cooper and Ritchie 1995). Kerlinger (1995) summarized radar results from the eastern United States and concluded that three-quarters of passerines migrate between 0 and 600 m agl.

We also examined the percentage of targets within the proposed maximal turbine height (i.e., 125 m agl) at this and other studies and found that 13–16% (for all ridge sites and only the central site, respectively) flew below 125 m at the proposed Mt. Storm development site, compared to 7–8% at 2 sites in Pennsylvania (J.

H. Plissner, ABR Inc., unpublished data), 4–9% at 3 sites in New York (T. J. Mabee, unpublished data), and 3–9% at 2 sites in the Pacific Northwest (Mabee and Cooper 2004). Because of methodological differences at these sites, however, these percentages may not be directly comparable.

We recorded large among-night variation in flight altitudes at the central site, similar to that observed in other studies (Cooper and Ritchie 1995, Cooper et al. 1995, Mabee and Cooper 2004). Mean flight altitudes always were above the maximal proposed turbine heights during autumn 2003; however, there were 5 nights when mean flight altitudes fell between 200 and 300 m agl. Weather conditions varied within and between nights, but 3 of the 5 nights had precipitation, low clouds (<500 m agl), and variable wind directions and speeds, whereas the remaining 2 nights had no precipitation, high clouds, and variable wind directions and speeds. Daily variation in flight altitudes probably reflected changes in both species composition and vertical structure of the atmosphere and weather. Kerlinger and Moore (1989), Bruderer et al. (1995), and Birgit et al. (2005) have concluded that atmospheric structure is the primary selective force determining the height at which migrants fly.

### **Did Migrants Follow the Allegheny Front Ridgeline?**

The Allegheny Front ridgeline is thought to be used as a leading line by some diurnal migrants (Hall and Bell 1981), but its role for nocturnal migrants is unknown. We used data on flight directions and flight path behaviors to address this question. Flight directions of targets among ridge sites and between the central

ridge site and the western (plateau) site were similar, and targets crossed over, rather than flew parallel to the main axis of the ridge. Similarly, most targets crossing the Allegheny Front showed little or no deviation in their flight paths when they passed over the ridge. In addition, strong correlations between overall flight directions of migrants crossing ridges near the KPBZ WSR-88D weather station near Pittsburgh, Pennsylvania (172 km northwest of our study area), and flight directions over our ridge sites further suggest that migration patterns did not vary with local topography. Thus, the main body of evidence suggests that at the scale of our observations, most nocturnal migrants did not follow along the Allegheny Front ridgeline during autumn migration.

Portable marine radars are flexible tools that, when coupled with a rigorous study design, can collect important baseline information on avian migration and address site-specific questions posed at proposed developments. In the future, concurrent collection of low-altitude migration and avian fatality data could help elucidate which metrics are most useful for predicting avian fatalities at wind power developments.

### **Acknowledgments**

We thank NedPower Mount Storm LLC for funding this study and R. Canterbury for help with selection of study sites. At ABR, we thank P. Sanzenbacher and C. Grinnell for help with radar sampling and manuscript preparation; A. Bradford, J. Felkay, and P. Odom for help with manuscript preparation; R. Blaha for figure preparation; and B. Day for reviewing the manuscript.

### **Literature Cited**

- Alerstam, T. 1990. Bird migration. Cambridge University, United Kingdom.
- Bellrose, F. C. 1971. The distribution of nocturnal migration in the air space. *Auk* 88:397–424.
- Bellrose, F. C. 1976. Ducks, geese and swans of North America. Second edition. Stackpole, Harrisburg, Pennsylvania, USA.
- Berthold, P. 1993. Bird migration: a general survey. Oxford University, New York, New York, USA.
- Birgit, E., F. Liechti, and B. Bruderer. 2005. The role of wind in passerine autumn migration between Europe and Africa. *Behavioral Ecology* 16:732–740.
- Blokpoel, H., and J. Burton. 1975. Weather and the height of nocturnal migration in east-central Alberta: a radar study. *Bird-Banding* 46:311–328.
- Bruderer, B., and A. Boldt. 2001. Flight characteristics of birds: I. Radar measurements of speeds. *Ibis* 143:178–204.
- Bruderer, B., and P. Steidinger. 1972. Methods of quantitative and qualitative analysis of bird migration with a tracking radar. Pages 151–168 in *Animal orientation and navigation: a symposium*. NASA SP262, Washington, D.C., USA.
- Bruderer, B., T. Steuri, and M. Baumgartner. 1995. Short-range high-precision surveillance of nocturnal migration and tracking of single targets. *Israeli Journal of Zoology* 41:207–220.
- Buckelew, A. R., Jr., and G. A. Hall. 1994. West Virginia breeding bird atlas. University of Pittsburgh, Pennsylvania, USA.
- Cooper, B. A., R. H. Day, R. J. Ritchie, and C. L. Cranor. 1991. An improved marine radar system for studies of bird migration. *Journal of Field Ornithology* 62:367–377.
- Cooper, B. A., C. B. Johnson, and E. F. Neuhauser. 1995. The impact of wind turbines in upstate New York. Pages 607–611 in *Proceedings of the Windpower '95 Conference*. American Wind Energy Association, 26–30 March 1995, Washington, D.C., USA.
- Cooper, B. A., and R. J. Ritchie. 1995. The altitude of bird migration in east-central Alaska: a radar and visual study. *Journal of Field Ornithology* 66:590–608.
- Diehl, R. H., R. P. Larkin, and J. E. Black. 2003. Radar observations of bird migration over the Great Lakes. *Auk* 120:278–290.
- Drury, W. H., and J. A. Keith. 1962. Radar studies of songbird migration in coastal New England. *Ibis* 104:449–489.
- Erickson, W. P., G. D. Johnson, M. D. Stickland, D. P. Young, Jr., K. J. Sernka, and R. E. Good. 2001. Avian collisions with wind turbines: a summary of existing studies and comparisons to other sources of avian collision mortality in the United States. National Wind Coordinating Committee, Washington, D.C., USA.
- Farnsworth, A., S. A. Gauthreaux, Jr., and D. Van Blaricom. 2004. A comparison of nocturnal call counts of migrating birds and reflectivity measurements on Doppler radar. *Journal of Avian Biology* 35:365–369.
- Gauthreaux, S. A., Jr. 1971. A radar and direct visual study of passerine spring migration in southern Louisiana. *Auk* 88:343–365.
- Gauthreaux, S. A., Jr. 1972. Behavioral responses of migrating birds to daylight and darkness: a radar and direct visual study. *Wilson Bulletin* 84:136–148.
- Gauthreaux, S. A., Jr. 1975. Radar ornithology: bird echoes on weather and airport surveillance radars. Clemson University, South Carolina, USA.
- Gauthreaux, S. A., Jr. 1991. The flight behavior of migrating birds in changing wind fields: radar and visual analyses. *American Zoologist* 31:187–204.
- Hall, G. A., and R. K. Bell. 1981. The diurnal migration of passerines along an Appalachian ridge. *American Birds* 35:135–138.
- Harmata, A. R., G. R. Leighty, and E. L. O'Neil. 2003. A vehicle-mounted radar for dual-purpose monitoring of birds. *Wildlife Society Bulletin* 31:882–886.
- Harmata, A. R., K. M. Podrzenski, J. R. Zelenak, and M. L. Morrison. 1999. Using marine surveillance radar to study bird movements and impact assessment. *Wildlife Society Bulletin* 27:44–52.
- Harmata, A. R., K. M. Podrzenski, J. R. Zelenak, and M. L. Morrison. 2000. Passage rates and timing of bird migration in Montana. *American Midland Naturalist* 143:30–40.
- Heintzelman, D. 1975. The migration of hawks. Indiana University, Bloomington, USA.
- Hunt, P. D., and B. C. Eliason. 1999. Blackpoll warbler (*Dendroica striata*). Account 431 in A. Poole and F. Gill, editors. *The birds of North America*. The



- Academy of Natural Sciences, Philadelphia, Pennsylvania, and The American Ornithologists' Union, Washington, D.C., USA.
- Hutto, R. L. 2000. On the importance of en route periods to the conservation of migratory landbirds. *Studies in Avian Biology* 20:109–114.
- Johnson, G. 2004. A review of bat impacts at wind farms in the U.S. Pages 46–50 in *Proceedings of the Wind Energy and Birds/Bats Workshop: understanding and resolving bird and bat impacts*. RESOLVE, 18–19 May 2004, Washington, D.C., USA.
- Kerlinger, P. 1995. *How birds migrate*. Stackpole, Mechanicsburg, Pennsylvania, USA.
- Kerlinger, P., and F. R. Moore. 1989. Atmospheric structure and avian migration. Pages 109–141 in D. M. Power, editor. *Current ornithology*. Volume 6. Plenum, New York, New York, USA.
- Kovach, W. 2003. *Oriana*. Version 2.0. Kovach Computing Services, Anglesey, United Kingdom.
- Kunz, T. H., and M. B. Fenton. 2003. *Bat ecology*. University of Chicago, Illinois, USA.
- Larkin, R. P. 1991. Flight speeds observed with radar, a correction: slow “birds” are insects. *Behavioral Ecology and Sociobiology* 29:221–224.
- Lowery, G. H., Jr. 1951. A quantitative study of the nocturnal migration of birds. *University of Kansas Museum of Natural History* 3:361–472.
- Mabee, T. J., and B. A. Cooper. 2004. Nocturnal bird migration in northeastern Oregon and southeastern Washington. *Northwestern Naturalist* 85:39–47.
- Orloff, S., and A. Flannery. 1992. Wind turbine effects on avian activity, habitat use, and mortality in Altamont Pass and Solano County WRA. Page 45 in S. Orloff and A. Flannery, editors. *Effects of wind energy development: an annotated bibliography*. California Energy Commission, Sacramento, USA.
- Osborn, R. G., K. F. Higgins, R. E. Usgard, C. D. Dieter, and R. D. Neiger. 2000. Bird mortality associated with wind turbines at the Buffalo Ridge Wind Resource Area, Minnesota. *American Midland Naturalist* 143:41–52.
- Statistical Package for the Social Sciences [SPSS]. 2002. *SPSS for Windows*. Version 11.5. SPSS, Chicago, Illinois, USA.
- Tuttle, M. D. 1988. *America's neighborhood bats*. University of Texas, Austin, USA.
- U.S. Fish and Wildlife Service. 2003. *Interim guidelines to avoid and minimize wildlife impacts from wind turbines*. <<http://www.fws.gov/habitatconservation/wind.pdf>>. Accessed 2006 Mar 13.
- Williams, T. C., J. M. Williams, L. C. Ireland, and J. M. Teal. 1977. Autumnal bird migration over the western North Atlantic Ocean. *American Birds* 31:251–267.
- Williams, T. C., J. M. Williams, P. G. Williams, and P. Stokstad. 2001. Bird migration through a mountain pass studied with high resolution radar, ceilometers, and census. *Auk* 118:389–403.
- Zalles, J. I., and K. L. Bildstein, editors. 2000. *Raptor watch: a global directory of raptor migration sites*. Birdlife International, Cambridge, United Kingdom, and Hawk Mountain Sanctuary, Kempton, Pennsylvania, USA.
- Zar, J. H. 1999. *Biostatistical analysis*. Third edition. Prentice-Hall, Englewood Cliffs, New Jersey, USA.



**Todd J. Mabee** (first photo, center) is a senior scientist with ABR, Inc.—Environmental Research & Services in Forest Grove, Oregon. He received a B.A. in Environmental, Population, and Organismic Biology from the University of Colorado, Boulder and an M.S. in zoology from Colorado State University. His research interests include the study of nocturnal bird migration throughout the United States, the breeding biology of shorebirds in the Midwest and Alaska, and the ecology of headwater amphibians in Oregon. **Brian A. Cooper** (first photo, left) is a senior scientist with ABR, Inc.—Environmental Research & Services in Forest Grove, Oregon. He earned his B.S. in wildlife biology from the University of Montana and an M.S. in biology from the University of Alaska, Fairbanks. His research interests include bird migration, seabird ecology, and radar ornithology. **Jonathan H. Plissner** (first photo, right) is a senior scientist with ABR, Inc.—Environmental Research & Services in Forest Grove, Oregon. He received a B.A. in biology from Cornell University and earned his Ph.D. in zoology at Clemson University. His research interests include the ecology of avian movements, especially patterns of dispersal and migration, and monitoring and modeling of populations. **David P. Young** (above) is a project manager with Western EcoSystems Technology, Inc. in Cheyenne, Wyoming. He received his B.A. (1986) from Earlham College and an M.S. (1988) from the University of Georgia. He has studied wind power and wildlife interactions since 1994 throughout the United States. His other professional interests and specialty areas include threatened and endangered species and wildlife and transportation system interactions.

Associate Editor: Jeff Bowman.

